

Bore Gages

For easy and accurate measurement of inside diameters

Bore Gages SERIES 526 — for Extra Small Holes

- These gages are designed to measure the diameters of very small holes.
- The indicator (dial indicator, Digimatic indicator) and dial protection cover are optional. Select an indicator from the recommended dial indicators and Digimatic indicators. Please contact us for advice when using an indicator other than the recommended indicators.
- An optional stand (**215-120-10**) is available for efficient measurement of multiple small holes. (Refer to page C-30 for details)



526-170-11

Note: The dial indicator and the protection cover are optional.

SPECIFICATIONS

Metric							
Order No.	Range (mm)	Accuracy (μm)	Repeatability (μm)	Bore gage	Dial indicator	Dial protection cover	Setting ring
526-170-10	0.95 - 1.55	4	1	526-170-10	Not supplied	Not supplied	Not supplied
526-160-10	1.50 - 3.95	4		526-160-10			
526-150-10	3.70 - 7.30	6		526-150-10			
526-172-20	0.95 - 1.55	4		526-170-10	2109AB-10 (Graduation: 0.001 mm)	21DZA000	
526-162-20	1.50 - 3.95	4		526-160-10			
526-152-20	3.70 - 7.30	6		526-150-10			
526-173-20	0.95 - 1.55	4		526-170-10	2046AB (Graduation: 0.01 mm)	21DZA000	
526-163-20	1.50 - 3.95	4		526-160-10			
526-153-20	3.70 - 7.30	6		526-150-10			
526-170-11	0.95 - 1.55	4		526-170-10	Not supplied	Not supplied	Supplied
526-160-11	1.50 - 3.95	4		526-160-10			
526-150-11	3.70 - 7.30	6		526-150-10			
526-172-21	0.95 - 1.55	4		526-170-10	2109AB-10 (Graduation: 0.001 mm)	21DZA000	
526-162-21	1.50 - 3.95	4		526-160-10			
526-152-21	3.70 - 7.30	6		526-150-10			
526-173-21	0.95 - 1.55	4		526-170-10	2046AB (Graduation: 0.01 mm)	21DZA000	
526-163-21	1.50 - 3.95	4	526-160-10				
526-153-21	3.70 - 7.30	6	526-150-10				

Inch							
Order No.	Range (in)	Accuracy (in)	Repeatability (in)	Bore gage	Dial indicator	Dial protection cover	Setting ring
526-175-10	0.037 - 0.061	0.00016	0.00004	526-175-10	Not supplied	Not supplied	Not supplied
526-165-10	0.059 - 0.156	0.00016		526-165-10			
526-155-10	0.146 - 0.287	0.00024		526-155-10			
526-176-20	0.037 - 0.061	0.00016		526-175-10	2923AB-10 (Graduation: 0.0001 in)	21DZA000	
526-166-20	0.059 - 0.156	0.00016		526-165-10			
526-156-20	0.146 - 0.287	0.00024		526-155-10			
526-175-11	0.037 - 0.061	0.00016		526-175-10	Not supplied	Not supplied	Supplied
526-165-11	0.059 - 0.156	0.00016		526-165-10			
526-155-11	0.146 - 0.287	0.00024		526-155-10			
526-176-21	0.037 - 0.061	0.00016		526-175-10	2923AB-10 (Graduation: 0.0001 in)	21DZA000	
526-166-21	0.059 - 0.156	0.00016		526-165-10			
526-156-21	0.146 - 0.287	0.00024		526-155-10			

Note: Setting rings are not supplied with some models. Please purchase them separately if necessary. For details of setting rings, refer to page C-47.



Measurement Principle

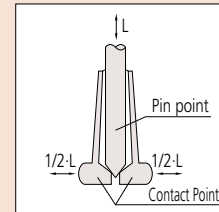

Setting Rings (Metric models)

Nominal size

- Order No. 526-170-11 etc.

177-220: 1.0 mm
177-222: 1.1 mm
177-225: 1.2 mm
177-227: 1.3 mm
177-230: 1.4 mm

- Order No. 526-160-11 etc.

177-236: 1.75 mm
177-239: 2.00 mm
177-242: 2.25 mm
177-208: 2.50 mm
177-246: 2.75 mm
177-248: 3.00 mm
177-250: 3.25 mm
177-252: 3.50 mm
177-255: 3.75 mm

- Order No. 526-150-11 etc.

177-204: 4.0 mm
177-257: 4.5 mm
177-205: 5.0 mm
177-263: 5.5 mm
177-267: 6.0 mm
177-271: 6.5 mm
177-275: 7.0 mm

Setting Rings (Inch models)

Nominal size

- Order No. 526-175-11 etc.

177-350: 0.040 in
177-351: 0.045 in
177-352: 0.050 in
177-353: 0.055 in
177-354: 0.060 in

- Order No. 526-165-11 etc.

177-355: 0.07 in
177-356: 0.08 in
177-357: 0.09 in
177-358: 0.10 in
177-359: 0.11 in
177-360: 0.12 in
177-361: 0.13 in
177-362: 0.14 in
177-363: 0.15 in

- Order No. 526-155-11 etc.

177-364: 0.16 in
177-365: 0.18 in
177-366: 0.20 in
177-367: 0.22 in
177-368: 0.24 in
177-369: 0.26 in
177-370: 0.28 in

DIMENSIONS

Optional Accessories

- Dial indicator (See Chapter F)
- Dial protection cover: **21DZA000** (See page C-45)
- Setting ring (See page C-47)
- Bore gage stand: **215-120-10** (See page C-30)

Recommended Dial Indicators (see Chapter F)

- Metric models: **2046AB** (0.01 mm)
2972AB (0.01 mm - One-revolution type)
2109AB-10 (0.001 mm)
2900AB-10 (0.001 mm - One-revolution type)
- Inch models: **2922AB** (0.0005 in)
2977AB (0.0005 in - One-revolution type)
2923AB-10 (0.0001 in)
2910AB-10 (0.0001 in - One-revolution type)

Recommended Digimatic Indicators (see page F-14)

- Metric models: **543-310B** (0.001 mm)
 - Inch models: **543-312B** (0.001 mm/0.00005 in)
- Note: Indicators equipped with rubber bellows, such as water-proof types, cannot be used.

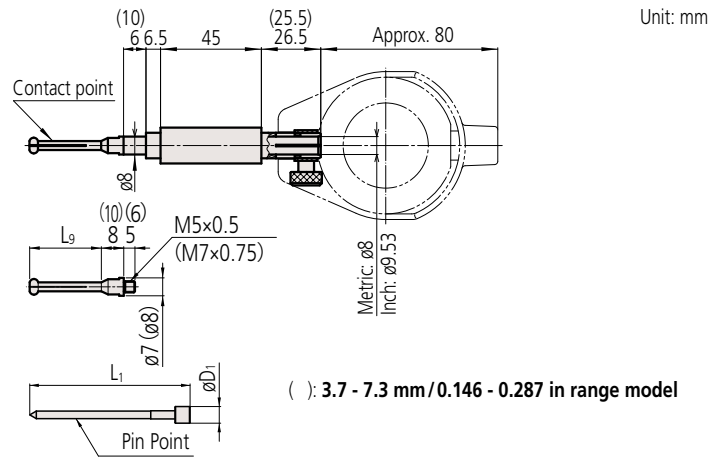

Bore gage (Main body)	Contact point				Pin point		
	Marked No.	Order No.	Range	L ₉	L ₁	øD ₁	Order No.
526-170-10 526-175-10	1.0	21DAA601A	0.95 - 1.15 mm/0.037 - 0.045 in	11.5	27.5	2.5	201435
	1.1	21DAA601B	1.07 - 1.25 mm/0.042 - 0.049 in				
	1.2	21DAA601C	1.17 - 1.35 mm/0.046 - 0.053 in				
	1.3	21DAA601D	1.27 - 1.45 mm/0.050 - 0.057 in				
	1.4	21DAA601E	1.37 - 1.55 mm/0.054 - 0.061 in				
526-160-10 526-165-10	1.75	21DAA602A	1.50 - 1.90 mm/0.059 - 0.075 in	17.5	33.8	3.5	201436
	2.00	21DAA602B	1.80 - 2.20 mm/0.071 - 0.087 in				
	2.25	21DAA602C	2.05 - 2.45 mm/0.081 - 0.096 in				
	2.50	21DAA602D	2.30 - 2.70 mm/0.091 - 0.106 in				
	2.75	21DAA602E	2.55 - 2.95 mm/0.100 - 0.116 in				
	3.00	21DAA602F	2.80 - 3.20 mm/0.110 - 0.126 in				
	3.25	21DAA602G	3.05 - 3.45 mm/0.120 - 0.136 in				
	3.50	21DAA602H	3.30 - 3.70 mm/0.130 - 0.146 in				
526-150-10 526-155-10	3.75	21DAA602J	3.55 - 3.95 mm/0.140 - 0.156 in	22.5	39.3	3.5	201437
	4.0	21DAA603A	3.7 - 4.3 mm/0.146 - 0.169 in				
	4.5	21DAA603B	4.2 - 4.8 mm/0.165 - 0.189 in				
	5.0	21DAA603C	4.7 - 5.3 mm/0.185 - 0.209 in				
	5.5	21DAA603D	5.2 - 5.8 mm/0.205 - 0.228 in				
	6.0	21DAA603E	5.7 - 6.3 mm/0.224 - 0.248 in				
	6.5	21DAA603F	6.2 - 6.8 mm/0.244 - 0.268 in				
7.0	21DAA603G	6.7 - 7.3 mm/0.264 - 0.287 in	32	53	5.5	201438	

Note: Pin point and contact point are consumable parts. Please replace them with new one when degrading of accuracy, operation, or measuring range. After replacement, calibrate using a reference instrument.

Spanner 210188

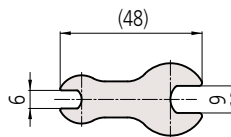

102148

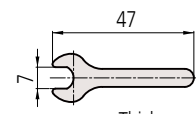

Thickness: 1.5

Extension rod 21AAA259E

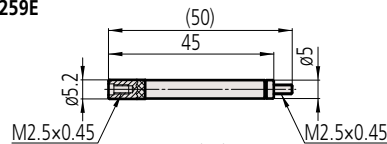

213634

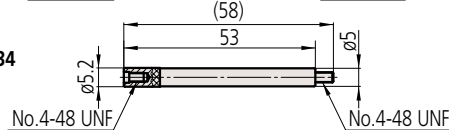

(): 3.7 - 7.3 mm/0.146 - 0.287 in range model

Bore gage	Spanner	Extension rod
526-170-10	210188	21AAA259E
526-160-10		
526-150-10	102148	213634
526-175-10	210188	
526-165-10	102148	
526-155-10		

Note: This is not a component for extending the probing depth. (Standard Accessory)