

Micrometer Head

The origin of Mitutoyo's trustworthy brand of small tool instruments

Micrometer Heads SERIES 153 — Non-rotating Spindle Type

- Micrometer head with non-rotating spindle.
- Torsion-free feed reduces workpiece deformation and wear.

Technical Data

- Measuring face
Material: Carbide
Hardness: 90 HRA or more
Lapped
- Scale finishing:
Satin-chrome plated

DIMENSIONS

Unit: mm



153-101 Mass: 70 g

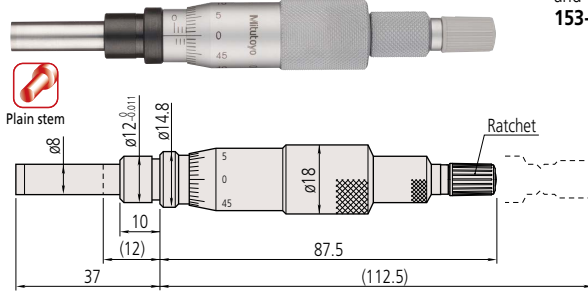
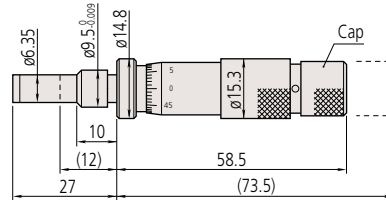

153-201 Mass: 125 g

Equipped with ratchet and vernier scale
153-202

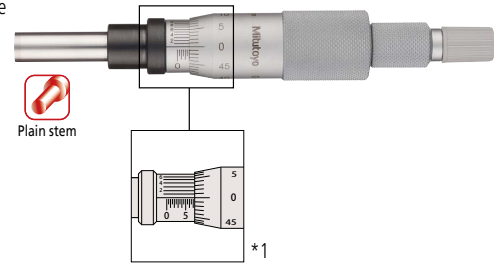

*1 Other dimensions are the same as **153-201**.

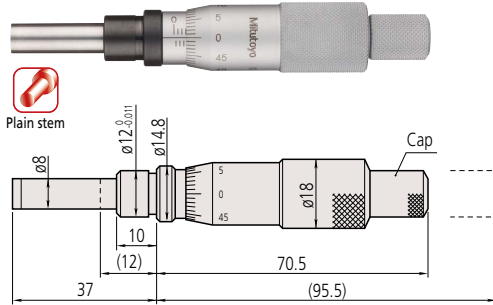

153-203 Mass: 125 g

Without ratchet / Equipped with vernier scale
153-204

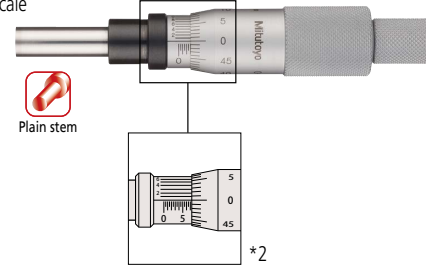

*2 Other dimensions are the same as **153-203**.
(): with spindle fully retracted.

SPECIFICATIONS

Metric

Order No.	Range (mm)	Graduation (mm)	Graduation features	Stem dia. (mm)	Stem	Spindle end	Spindle pitch (mm)	Maximum permissible error J_{MPE} (μm)
153-101	0 - 15	0.01	Standard	9.5	Plain	Flat (carbide tip)	0.5	± 3
153-201 *1								
153-202 *1	0 - 25	0.001	W/vernier (0.001 mm)	12	Plain	Flat (carbide tip)	0.5	± 3
153-203		0.01	Standard					
153-204		0.001	W/vernier (0.001 mm)					

Inch

Order No.	Range (in)	Graduation (in)	Special features	Stem dia. (in)	Stem	Spindle end	Spindle pitch (in)	Maximum permissible error J_{MPE} (in)
153-108 *2	0 - 0.5	0.001	W/vernier (0.0001 in)	0.375	Plain	Flat (carbide tip)	0.025	± 0.00015
153-205 *1			Standard					
153-206 *1	0 - 1	0.0001	W/vernier (0.0001 in)	0.5	Plain	Flat (carbide tip)	0.025	± 0.00015
153-207		0.001	Standard					
153-208		0.0001	W/vernier (0.0001 in)					

*1 With ratchet stop *2 Made-to-order model