

### Technical Data

- Measuring face  
Material: Carbide  
Hardness: 90 HRA or more  
Lapped
- Scale finishing:  
Satin-chrome plated

## Micrometer Heads SERIES 152 — Quick Spindle Feed of 1 mm/rev

- Micrometer head with 1 mm spindle pitch enables quick feeding and positioning.
- The larger screw thread also provides greater load-bearing capacity than does a standard head.

### DIMENSIONS

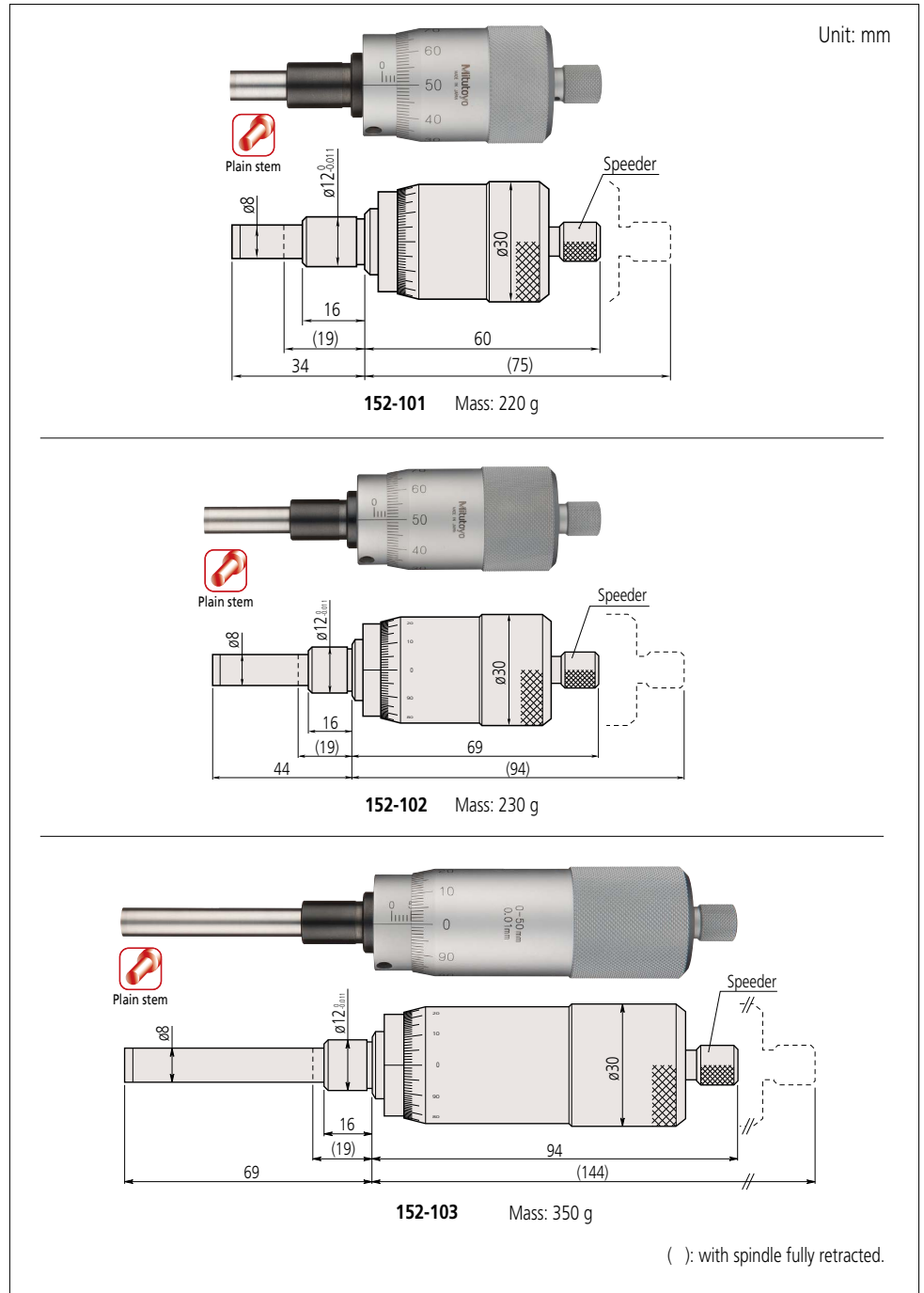

### SPECIFICATIONS

Metric							
Order No.	Range (mm)	Graduation (mm)	Stem dia. (mm)	Stem	Spindle end	Spindle pitch (mm)	Maximum permissible error $J_{MPE}$ ( $\mu\text{m}$ )
152-101	0 - 15	0.01	12	Plain	Flat (carbide tip)	1	$\pm 2$
152-102	0 - 25						$\pm 2$
152-103	0 - 50						$\pm 4$