

Can Seam Micrometers SERIES 147

Measurement example



- Measures the width, height, and depth of can seams.



147-103

SPECIFICATIONS

Metric				
Order No.	Range (mm)	Graduation (mm)	Maximum permissible error J_{MPE} (μm)	Remarks
147-103	0 - 13	0.01	± 3	—
147-105				for aluminum cans
147-202				for spray cans

Inch				
Order No.	Range (in)	Graduation (in)	Maximum permissible error J_{MPE} (in)	Remarks
147-104	0 - 0.5	0.001	± 0.00015	—
147-106				for aluminum cans
147-201				for spray cans

• Standard Accessories: Spanner (200168), 1 pc. Spanner (202863), 1 pc.

DIMENSIONS

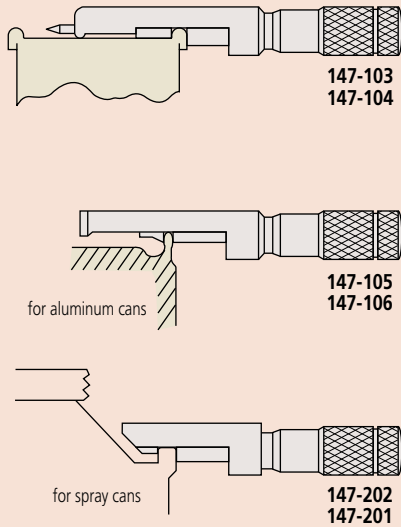
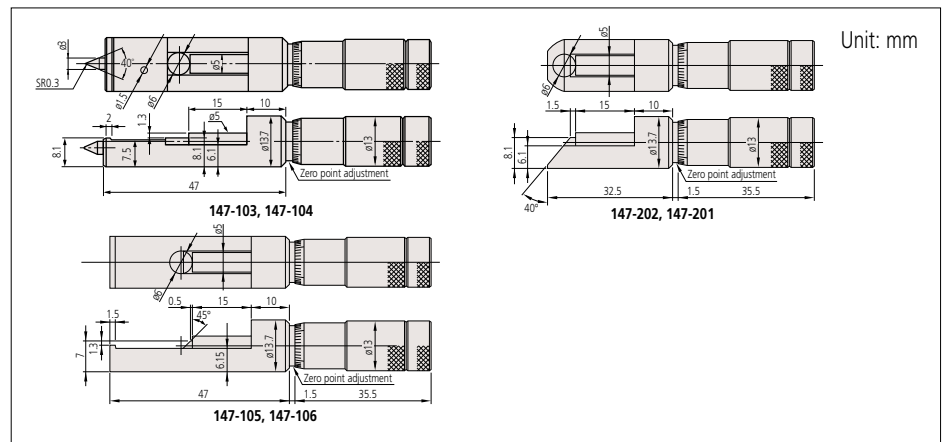

Hub Micrometers SERIES 147

- Measures hub thickness and shoulders inside a bore.
- Measuring faces: Carbide.
- Equipped with Ratchet Stop for constant measuring force.



147-301

SPECIFICATIONS

Metric					
Order No.	Range (mm)	Graduation (mm)	Maximum permissible error J_{MPE} (μm)	Flatness (μm)	Parallelism (μm)
147-301	0 - 25	0.01	± 2	0.6	3
147-302	25 - 50				
147-303	50 - 75				
147-304	75 - 100				

Inch					
Order No.	Range (in)	Graduation (in)	Maximum permissible error J_{MPE} (in)	Flatness (in)	Parallelism (in)
147-351	0 - 1	0.001	± 0.0001	0.00024	0.00012
147-352	1 - 2				
147-353	2 - 3				
147-354	3 - 4				

• Standard Accessories: Setting standard, 1 pc. (except for measuring range 0 to 25 mm (0 to 1 in) models), Spanner (301336), 1 pc.

DIMENSIONS

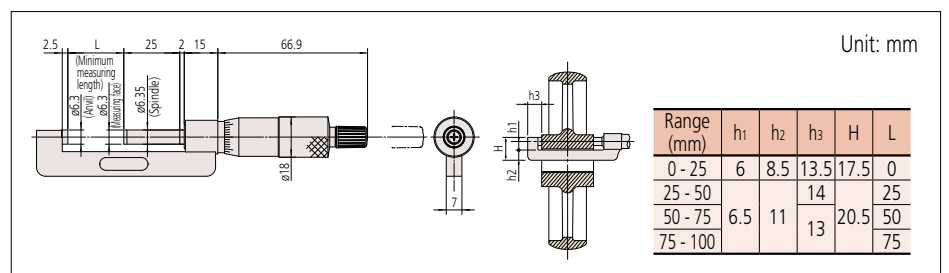

Measurement example

