

Bore Gages

Bore Gages SERIES 526 — for Extra Small Holes

- This series allows for agile and highly accurate comparative measurement of $\varnothing 7$ to 18 mm inside diameters.
- We offer an array of indicators. Contact us if you prefer any indicator other than the standard recommended indicator.
- Optional stand (**215-120-10**) is available for efficient measurement of multiple small holes.



526-101

Note: The dial indicator and the dial protection cover are optional.

SPECIFICATIONS

Metric							
Order No.	Range (mm)	Accuracy* (μm)	Repeatability* (in)	Bore gage	Dial indicator	Dial protection cover	Setting ring
526-101	7 - 10	4	2	526-101	Not supplied	Not supplied	Not supplied
526-102	10 - 18	6		526-102			
526-124-20	7 - 10	4		526-101	2109AB-10 (Graduation: 0.001 mm)	21DZA000	
526-125-20	10 - 18	6		526-102			
526-126-20	7 - 10	4		526-101	2046AB (Graduation: 0.01 mm)	21DZA000	
526-127-20	10 - 18	6		526-102			
Inch							
Order No.	Range (in)	Accuracy* (in)	Repeatability* (in)	Bore gage	Dial indicator	Dial protection cover	Setting ring
526-103	0.3 - 0.4	0.00016	0.00008	526-103	Not supplied	Not supplied	Not supplied
526-104	0.4 - 0.7	0.00024		526-104			
526-122-20	0.3 - 0.4	0.00016		526-103	2923AB-10 (Graduation: 0.0001 in)	21DZA000	
526-123-20	0.4 - 0.7	0.00024		526-104			
526-119-20	0.3 - 0.4	0.00016		526-103	2922AB (Graduation: 0.0005 in)	21DZA000	
526-120-20	0.4 - 0.7	0.00024		526-104			

* Accuracy of the bore gage alone.

Note: Setting rings are not supplied.

Please purchase them separately if necessary. For details of the setting rings, refer to page C-52.

DIMENSIONS

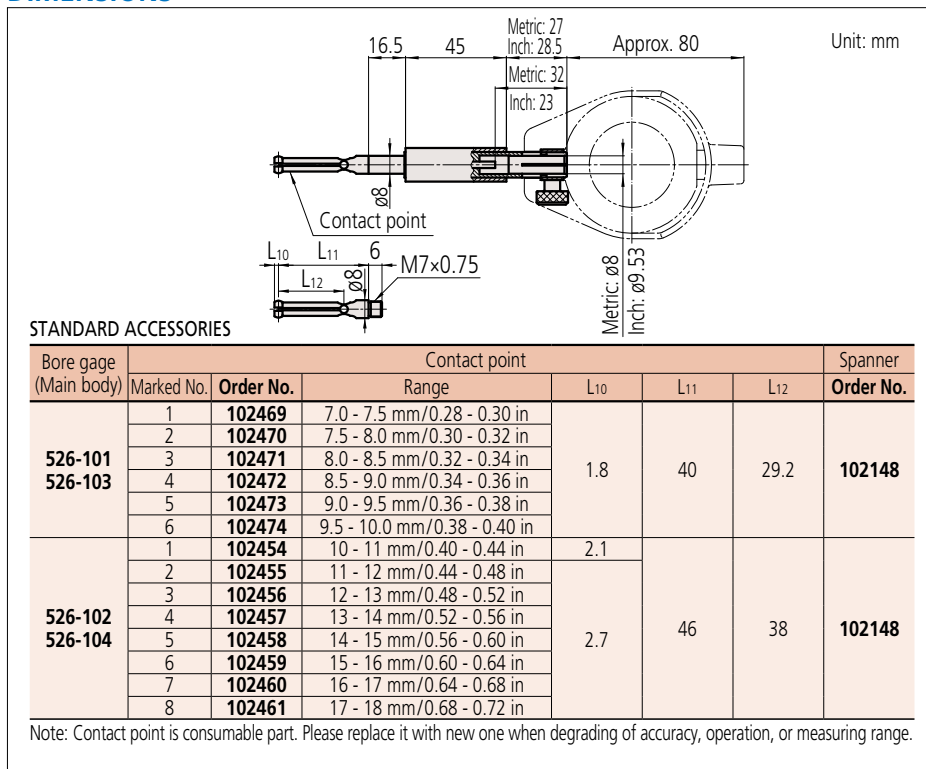

STANDARD ACCESSORIES

Bore gage (Main body)	Contact point						Spanner Order No.
	Marked No.	Order No.	Range	L ₁₀	L ₁₁	L ₁₂	
526-101 526-103	1	102469	7.0 - 7.5 mm/0.28 - 0.30 in	1.8	40	29.2	102148
	2	102470	7.5 - 8.0 mm/0.30 - 0.32 in				
	3	102471	8.0 - 8.5 mm/0.32 - 0.34 in				
	4	102472	8.5 - 9.0 mm/0.34 - 0.36 in				
	5	102473	9.0 - 9.5 mm/0.36 - 0.38 in				
	6	102474	9.5 - 10.0 mm/0.38 - 0.40 in				
526-102 526-104	1	102454	10 - 11 mm/0.40 - 0.44 in	2.7	46	38	102148
	2	102455	11 - 12 mm/0.44 - 0.48 in				
	3	102456	12 - 13 mm/0.48 - 0.52 in				
	4	102457	13 - 14 mm/0.52 - 0.56 in				
	5	102458	14 - 15 mm/0.56 - 0.60 in				
	6	102459	15 - 16 mm/0.60 - 0.64 in				
	7	102460	16 - 17 mm/0.64 - 0.68 in				
	8	102461	17 - 18 mm/0.68 - 0.72 in				

Note: Contact point is consumable part. Please replace it with new one when degrading of accuracy, operation, or measuring range.

Measurement example



Measurement Principle

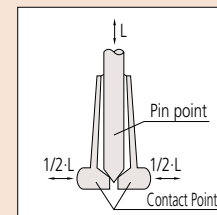

The dial protection cover, recommended indicators

Refer to page C-50.

Spanner 102148

