

Setting Rings

SERIES 177 — Accessories for Inside Micrometers, Holtest and Dial Bore Gages

Made-to-order

- Custom-made setting rings
Mitutoyo can manufacture setting rings to your size and design.
- Nominal size range
1 mm to 305 mm (steel)
4 mm to 50 mm (ceramic)
- Nominal size increment
0.01 mm (up to 45 mm)
0.02 mm (over 45 mm)

- Used for quick and accurate setting of dial bore gages, Holtest, and inside micrometers.

- Actual diameter is marked in 0.001 mm increments. (Dimension measuring position is the center of the height T.)

Steel Setting Rings



177-300

CERA Setting Rings



177-432

DIMENSIONS

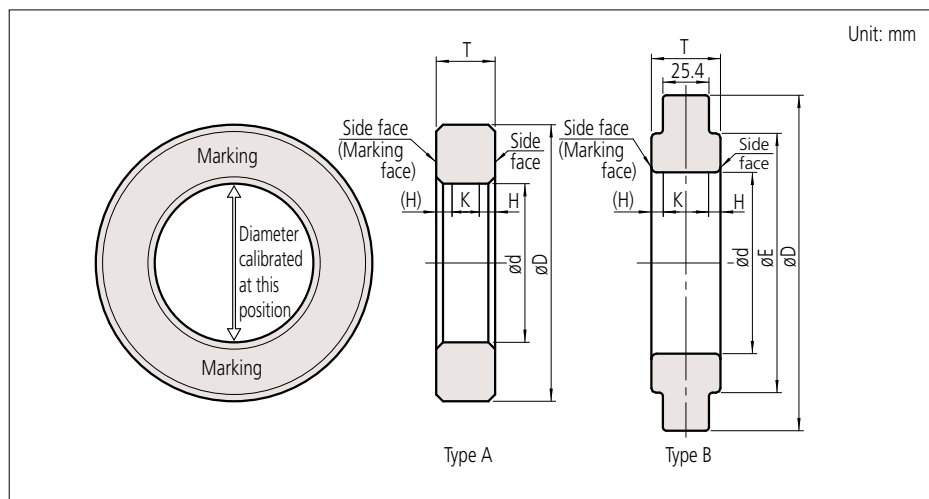

Suffix

177-*-62:** With Inspection Certificate (provides a record of the calibrated diameter) and Calibration Certificate

177-*-82:** With Inspection Certificate (provides a record of the calibrated diameter), Calibration Certificate, and Traceability System Chart

Note 1: The Inspection Certificate is not a substitute for a calibration certificate as it is undated.

Note 2: A more detailed inspection certificate describing roundness and cylindricity is available on request.

Bore Gages

Setting Rings

SERIES 177 — Accessories for Inside Micrometers, Holtest and Dial Bore Gages

SPECIFICATIONS

Steel Setting Rings

Metric										
Order No.	Nominal size ϕ D (mm)	Dimensions (mm)			Type	Accuracy				
		ϕ D	ϕ E	T		Tolerance between the nominal size and the actual diameter (μ m)	Uncertainty of marked diameter value*1 (μ m)	Roundness/Cylindricity*2 (μ m)	Distance from the side face H (mm)	Size of warranted calibration surface K (mm)
177-220	1	20	—	4	A	± 10	1.5	1.0	1.6	0.8
177-222	1.1	20	—	4	A	± 10	1.5	1.0	1.6	0.8
177-225	1.2	20	—	4	A	± 10	1.5	1.0	1.6	0.8
177-227	1.3	20	—	4	A	± 10	1.5	1.0	1.6	0.8
177-230	1.4	20	—	4	A	± 10	1.5	1.0	1.6	0.8
177-236	1.75	25	—	5	A	± 10	1.5	1.0	1.6	1.8
177-239	2	25	—	5	A	± 10	1.5	1.0	1.6	1.8
177-242	2.25	25	—	5	A	± 10	1.5	1.0	1.6	1.8
177-208	2.5	25	—	7	A	± 10	1.5	1.0	1.7	3.6
177-246	2.75	25	—	7	A	± 10	1.5	1.0	1.7	3.6
177-248	3	25	—	7	A	± 10	1.5	1.0	1.7	3.6
177-250	3.25	25	—	7	A	± 10	1.5	1.0	1.7	3.6
177-252	3.5	25	—	7	A	± 10	1.5	1.0	1.7	3.6
177-255	3.75	25	—	7	A	± 10	1.5	1.0	1.7	3.6
177-204	4	25	—	7	A	± 10	1.5	1.0	1.7	3.6
177-257	4.5	25	—	7	A	± 10	1.5	1.0	1.7	3.6
177-205	5	25	—	7	A	± 10	1.5	1.0	1.7	3.6
177-263	5.5	25	—	7	A	± 10	1.5	1.0	1.7	3.6
177-267	6	25	—	7	A	± 10	1.5	1.0	1.7	3.6
177-271	6.5	25	—	7	A	± 10	1.5	1.0	1.7	3.6
177-275	7	25	—	7	A	± 10	1.5	1.0	1.7	3.6
177-125	8	32	—	10	A	± 10	1.5	1.0	2.0	6.0
177-279	9	32	—	10	A	± 10	1.5	1.0	2.0	6.0
177-126	10	32	—	10	A	± 10	1.5	1.0	2.0	6.0
177-284	12	32	—	10	A	± 10	1.5	1.0	2.0	6.0
177-132	14	38	—	10	A	± 10	1.5	1.0	2.0	6.0
177-177	16	45	—	10	A	± 10	1.5	1.0	2.0	6.0
177-133	17	45	—	10	A	± 10	1.5	1.0	2.0	6.0
177-285	18	45	—	10	A	± 10	1.5	1.0	2.0	6.0
177-286	20	45	—	10	A	± 10	1.5	1.0	2.0	6.0
177-139	25	53	—	15	A	± 10	1.5	1.0	3.2	8.6
177-288	30	71	—	15	A	± 10	1.5	1.0	3.2	8.6
177-140	35	71	—	15	A	± 10	1.5	1.0	3.2	8.6
177-290	40	71	—	15	A	± 10	1.5	1.0	3.2	8.6
177-178	45	85	—	15	A	± 10	1.5	1.0	3.7	7.6
177-146	50	85	—	20	A	± 20	1.5	1.0	3.7	12.6
177-292	60	112	—	20	A	± 20	1.5	1.0	3.7	12.6
177-314	62	112	—	20	A	± 20	1.5	1.5	3.7	12.6
177-147	70	112	—	20	A	± 20	1.5	1.5	3.7	12.6
177-316	75	125	—	25	A	± 20	1.5	1.5	4.2	16.6
177-294	80	125	—	25	A	± 20	1.5	1.5	4.2	16.6
177-318	87	140	—	25	A	± 20	1.5	1.5	4.2	16.6
177-148	90	140	—	25	A	± 20	1.5	1.5	4.2	16.6
177-296	100	160	—	25	A	± 20	1.5	2.0	4.2	16.6
177-298	125	210	168	38.1 (25.4)	B	± 20	2.5	2.0	5.3	27.5
177-300	150	235	187		B	± 20	2.5	2.0	5.3	27.5
177-302	175	260	215		B	± 20	2.5	2.5	5.3	27.5
177-304	200	311	244		B	± 20	2.5	2.5	5.3	27.5
177-306	225	337	264		B	± 20	2.5	2.5	5.3	27.5
177-308	250	362	290		B	± 20	2.5	3.0	5.3	27.5
177-310	275	413	321		B	± 20	2.5	3.0	5.3	27.5
177-312	300	438	340		B	± 20	2.5	3.0	5.3	27.5

*1 Actual diameter is marked in 0.001 mm increments. (Dimension measuring position is the center of the height T.)

*2 Cylindricity is defined as per JIS B 0621 Definitions and designations of geometrical deviations, Section 4.4 "Cylindricity."

Cylindricity is measured using three cross-sections between the top and bottom face of a ring, namely, close to the face near each side and the center.

Inch

Order No.	Nominal size ϕD (in)	Dimensions (mm)			Type	Accuracy				
		ϕD	ϕE	T		Tolerance between the nominal size and the actual diameter (in)	Uncertainty of marked diameter value*1 (in)	Roundness/Cylindricity*2 (in)	Distance from the side face H (mm)	Size of warranted calibration surface K (mm)
177-209	0.1	25	—	7	A	± 0.0004	0.00006	0.00004	1.7	3.6
177-206	0.16	25	—	7	A	± 0.0004	0.00006	0.00004	1.7	3.6
177-207	0.24	25	—	7	A	± 0.0004	0.00006	0.00004	1.7	3.6
177-281	0.275	25	—	7	A	± 0.0004	0.00006	0.00004	2.0	3.0
177-179	0.35	32	—	10	A	± 0.0004	0.00006	0.00004	2.0	6.0
177-283	0.425	32	—	10	A	± 0.0004	0.00006	0.00004	2.0	6.0
177-180	0.5	32	—	10	A	± 0.0004	0.00006	0.00004	2.0	6.0
177-181	0.6	38	—	10	A	± 0.0004	0.00006	0.00004	2.0	6.0
177-182	0.65	45	—	10	A	± 0.0004	0.00006	0.00004	2.0	6.0
177-183	0.7	45	—	10	A	± 0.0004	0.00006	0.00004	2.0	6.0
177-287	0.8	45	—	10	A	± 0.0004	0.00006	0.00004	2.0	6.0
177-184	1	53	—	15	A	± 0.0004	0.00006	0.00004	3.2	8.6
177-289	1.2	71	—	15	A	± 0.0004	0.00006	0.00004	3.2	8.6
177-185	1.4	71	—	15	A	± 0.0004	0.00006	0.00004	3.2	8.6
177-291	1.6	71	—	15	A	± 0.0004	0.00006	0.00004	3.2	8.6
177-186	1.8	85	—	15	A	± 0.0004	0.00006	0.00004	3.7	7.6
177-187	2	85	—	20	A	± 0.0008	0.00006	0.00004	3.7	12.6
177-293	2.4	112	—	20	A	± 0.0008	0.00006	0.00004	3.7	12.6
177-315	2.5	112	—	20	A	± 0.0008	0.00006	0.00006	4.2	11.6
177-188	2.8	112	—	20	A	± 0.0008	0.00006	0.00006	4.2	11.6
177-317	3	125	—	25	A	± 0.0008	0.00006	0.00006	4.2	16.6
177-295	3.2	125	—	25	A	± 0.0008	0.00006	0.00006	4.2	16.6
177-319	3.5	140	—	25	A	± 0.0008	0.00006	0.00006	4.2	16.6
177-189	3.6	140	—	25	A	± 0.0008	0.00006	0.00006	4.2	16.6
177-297	4	160	—	25	A	± 0.0008	0.00006	0.00008	4.2	16.6
177-299	5	210	168	38.1	B	± 0.0008	0.00010	0.00008	5.3	27.5
177-301	6	235	187	38.1	B	± 0.0008	0.00010	0.00008	5.3	27.5
177-303	7	260	215	38.1	B	± 0.0008	0.00010	0.00010	5.3	27.5
177-305	8	311	244	38.1	B	± 0.0008	0.00010	0.00010	5.3	27.5
177-307	9	337	264	38.1	B	± 0.0008	0.00010	0.00010	5.3	27.5
177-309	10	362	290	38.1	B	± 0.0008	0.00010	0.00012	5.3	27.5
177-311	11	413	321	38.1	B	± 0.0008	0.00010	0.00012	5.3	27.5
177-313	12	438	340	38.1	B	± 0.0008	0.00010	0.00012	5.3	27.5

*1 Actual diameter is marked in 0.001 mm increments. (Dimension measuring position is the center of the height T.)

*2 Cylindricity is defined as per JIS B 0621 Definitions and designations of geometrical deviations, Section 4.4 "Cylindricity." Cylindricity is measured using three cross-sections between the top and bottom face of a ring, namely, close to the face near each side and the center.

Bore Gages

Setting Rings

SERIES 177 — Accessories for Inside Micrometers, Holtest and Dial Bore Gages

SPECIFICATIONS

CERA Setting Rings

Metric										
Order No.	Nominal size ϕ d (mm)	Dimensions (mm)			Type	Accuracy				
		ϕ D	ϕ E	T		Tolerance between the nominal size and the actual diameter (μ m)	Uncertainty of marked diameter value*1 (μ m)	Roundness/Cylindricity*2 (μ m)	Distance from the side face H (mm)	Size of warranted calibration surface K (mm)
177-418	4	25	—	7	A	± 10	1.5	1.0	1.7	3.6
177-420	6	25	—	7	A	± 10	1.5	1.0	1.7	3.6
177-423	8	32	—	10	A	± 10	1.5	1.0	2.0	6.0
177-424	10	32	—	10	A	± 10	1.5	1.0	2.0	6.0
177-425	12	32	—	10	A	± 10	1.5	1.0	2.0	6.0
177-427	16	45	—	10	A	± 10	1.5	1.0	2.0	6.0
177-429	20	45	—	10	A	± 10	1.5	1.0	2.0	6.0
177-430	25	53	—	15	A	± 10	1.5	1.0	3.2	8.6
177-431	30	71	—	15	A	± 10	1.5	1.0	3.2	8.6
177-432	35	71	—	15	A	± 10	1.5	1.0	3.2	8.6
177-433	40	71	—	15	A	± 10	1.5	1.0	3.2	8.6
177-434	45	85	—	15	A	± 10	1.5	1.0	3.7	7.6

Inch										
Order No.	Nominal size ϕ d (in)	Dimensions (mm)			Type	Accuracy				
		ϕ D	ϕ E	T		Tolerance between the nominal size and the actual diameter (in)	Uncertainty of marked diameter value*1 (in)	Roundness/Cylindricity*2 (in)	Distance from the side face H (mm)	Size of warranted calibration surface K (mm)
177-518	0.16	25	—	7	A	± 0.0004	0.00006	0.00004	1.7	3.6
177-520	0.24	25	—	7	A	± 0.0004	0.00006	0.00004	1.7	3.6
177-522	0.275	25	—	7	A	± 0.0004	0.00006	0.00004	1.7	3.6
177-523	0.35	32	—	10	A	± 0.0004	0.00006	0.00004	2.0	6.0
177-524	0.425	32	—	10	A	± 0.0004	0.00006	0.00004	2.0	6.0
177-525	0.5	32	—	10	A	± 0.0004	0.00006	0.00004	2.0	6.0
177-527	0.65	45	—	10	A	± 0.0004	0.00006	0.00004	2.0	6.0
177-529	0.8	45	—	10	A	± 0.0004	0.00006	0.00004	2.0	6.0
177-530	1	53	—	15	A	± 0.0004	0.00006	0.00004	3.2	8.6
177-531	1.2	71	—	15	A	± 0.0004	0.00006	0.00004	3.2	8.6
177-532	1.4	71	—	15	A	± 0.0004	0.00006	0.00004	3.2	8.6
177-533	1.6	71	—	15	A	± 0.0004	0.00006	0.00004	3.2	8.6
177-534	1.8	85	—	15	A	± 0.0004	0.00006	0.00004	3.7	7.6

*1 Actual diameter is marked in 0.001 mm increments. (Dimension measuring position is the center of the height T.)

*2 Cylindricity is defined as per JIS B 0621 Definitions and designations of geometrical deviations, Section 4.4 "Cylindricity."

Cylindricity is measured using three cross-sections between the top and bottom face of a ring, namely, close to the face near each side and the center.