

Typical application

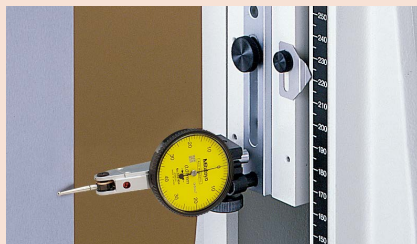

Mounting the Indicator Holder

Example 1

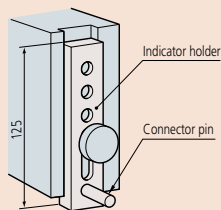

Example 2

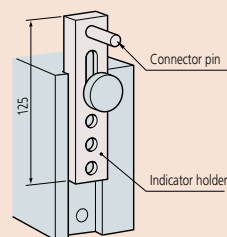

Standard Accessories

- 513-401-10H (Metric)
- 902053: Clamp
- 601471: Indicator holder
- 538616: Hexagonal-head wrench (3 mm)

Note: Inspection certificate is not attached. Contact your local Mitutoyo sales office.

Optional Accessories

- 900565: Feeler
- 900571: Adjustable holder
- 900551: Extension holder

Square Master
SERIES 311 — Squareness/Straightness Measuring

- Squareness (perpendicularity) and straightness measurements can be performed accurately and efficiently by just moving a lever. Use the vertical motion handle on the rear of the main unit for operation.
- Sliding force: Approx. 2 to 5 N
- Highly accurate measurement of squareness and straightness is available by calibrating a square as a master using the built-in perpendicularity adjustment mechanism. Prepare a square to be used for accuracy check/adjustment separately.



311-215



311-225



311-245

SPECIFICATIONS

Order No.	Vertical travel (mm)	Squareness (μm)	Straightness (μm)	Dimension (mm)			Mass (kg)
				Width	Depth	Height	
311-215*	150	3	2	180	200	420	13.7
311-225*	250	6	2.5	180	200	520	16.2
311-245	450	9	3.5	220	220	720	24

* Riser blocks to extend the height of Square Masters can be used. (Refer to Page E-36 for details)

Optional accessories

900565: Feeler

For probing surfaces that the contact point of a detector cannot reach.

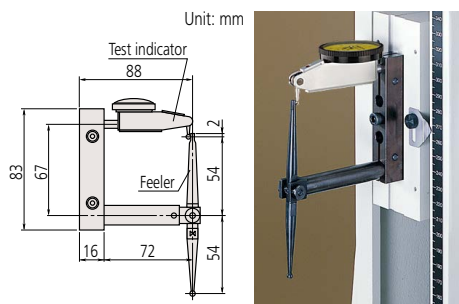

900571: Adjustable holder

Enables easy adjustment of indicator position.

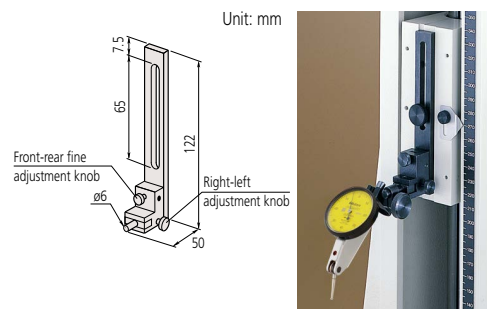

900551: Extension holder

Measurement position can be extended by using this 200 mm length holder instead of the indicator holder.

