



Dust- and
Water-
Protected
www.mitutoyo.com
ID 000000191

Applicable models: series 326

Measurement example



Optional Accessories (for series 326)

Order No.	Type	Description
05CZA662	B	Connecting cable (1 m)
05CZA663	B	Connecting cable (2 m)
06AFM380B	B	USB Input Tool Direct (2 m)
02AZD790B	B	Connecting cables for U-WAVE-T (160 mm)
02AZE140B	B	Connecting cables for U-WAVE-T For foot switch
264-622	IP67	U-WAVE-TM
264-623	Buzzer	U-WAVE-TM
264-626	IP67	U-WAVE-TMB
264-627	Buzzer	U-WAVE-TMB
02AZF310	IP67/ buzzer	Connecting unit for U-WAVE-TM/TMB

• For Metric/Unified threads (pair)

Order No.	Matching anvils/spindle tips included (mm)
126-801	0.4 - 0.5/64 - 48 TPI
126-802	0.6 - 0.9/44 - 28 TPI
126-803	1 - 1.75/24 - 14 TPI
126-804	2 - 3/13 - 9 TPI
126-805	3.5 - 5/8 - 5 TPI
126-806	5.5 - 7/4.5 - 3.5 TPI
126-800	Set with one each of 126-801 to 126-806

• For Whitworth threads (pair)

Order No.	Matching anvils/spindle tips included (mm)	Order No.	Matching anvils/spindle tips included (mm)
126-811	64 - 48 TPI	126-817	14 - 10 TPI
126-812	48 - 40 TPI	126-818	10 - 7 TPI
126-813	40 - 32 TPI	126-819	7 - 4.5 TPI
126-814	32 - 24 TPI	126-820	4.5 - 3.5 TPI
126-815	24 - 18 TPI	126-810	Set with one each of 126-811 to 126-820
126-816	18 - 14 TPI		

Screw Thread Micrometers
SERIES 326, 126 — Interchangeable Anvil/Spindle Tip Type

- Use by installing a suitable interchangeable anvil/spindle tip pair.
- Direct reading of screw pitch diameter (no need for calculation).
- **Series 326** is a protection grade IP65, waterproof Digimatic screw thread micrometer with interchangeable anvil/spindle tip.
- Equipped with Ratchet Stop for constant measuring force.
- Supplied with a setting standard for adjusting zero point for metric (unified) 60° threads.
- Interchangeable anvils/spindle tips are optional.



Interchangeable anvils/
spindle tips (optional)

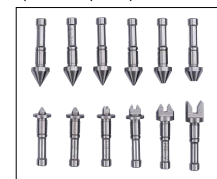

SPECIFICATIONS

Metric			
Order No.	Range (mm)	Resolution (mm)	Spindle feed error (µm)
Digimatic (LCD)			
326-251-30	0 - 25	0.001	3
326-252-30	25 - 50		
326-253-30	50 - 75		
326-254-30	75 - 100		

Inch / Metric			
Order No.	Range (in)	Resolution	Spindle feed error (in)
Digimatic (LCD)			
326-351-30	0 - 1	0.00005 in/ 0.001 mm	0.00015
326-352-30	1 - 2		
326-353-30	2 - 3		
326-354-30	3 - 4		

- Battery: SR44 (1 pc.), **938882**, for initial operational checks (standard accessory)
- Battery life: Approx. 2.4 years under normal use
- Length standard: Electromagnetic rotary sensor
- Standard Accessories: Spanner (**301336**), 1 pc.

Note 1: A matching setting standard is supplied with each model (except for 0 to 25 mm measuring range). (Refer to page B-70 for details.) The setting standard is for metric threads (unified) 60°.

Note 2: For functional details, refer to page B-7. Please note that origin setting of these models is by presetting. Optional connecting cable is available only for water-proof type (Digimatic model).



SPECIFICATIONS

Metric			
Order No.	Range (mm)	Graduation (mm)	Spindle feed error (µm)
Analog			
126-125	0 - 25	0.01	3
126-126	25 - 50		
126-127	50 - 75		
126-128	75 - 100		
126-129	100 - 125		
126-130	125 - 150		
126-131	150 - 175		
126-132	175 - 200		
126-133	200 - 225		
126-134	225 - 250		
126-135	250 - 275		
126-136	275 - 300		

Inch			
Order No.	Range (in)	Graduation (in)	Spindle feed error (in)
Analog			
126-137	0 - 1	0.001	0.00015
126-138	1 - 2		
126-139	2 - 3		
126-140	3 - 4		
126-141	4 - 5		
126-142	5 - 6		
126-143	6 - 7		

- Standard Accessories: Spanner (**301336**), 1 pc.

Note: A matching setting standard is supplied with each model (except for 0 to 25 mm measuring range). (Refer to page B-70 for details.) The setting standard is for metric threads (unified) 60°.

Micrometer

Screw Thread Micrometers SERIES 326, 126 — Interchangeable Anvil/Spindle Tip Type

DIMENSIONS

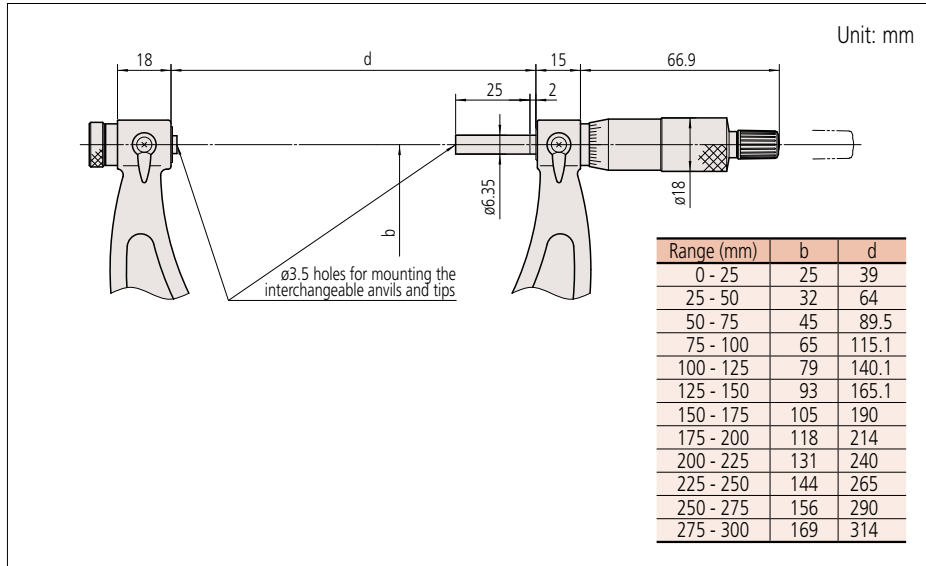

Technical description

- Anvils/spindle tips

- Allowable error of the angle of anvils and spindle tips

Type	Metric (Unified)	Whitworth (Unified)	Half angle error α
Pitch (mm), Nominal designation of threads per inch		W1	$\pm 30'$
	M1 (U1)	W2	$\pm 30'$
		W3	$\pm 20'$
	M2 (U2)	W4	$\pm 20'$
		W5	$\pm 15'$
	M3 (U3)	W6	$\pm 15'$
	M4 (U4)	W7	$\pm 10'$
		W8	$\pm 10'$
	M5 (U5)	W9	$\pm 10'$
	M6 (U6)	W10	$\pm 10'$

Note: This chart indicates the difference between the angle made by anvil's contact faces and spindle's axes and the half angle with error α .
Metric/Unified $\theta=60^\circ$
Whitworth $\theta=55^\circ$